

IEEE Standard Tests for Determining Compatibility of Cable-Pulling Lubricants With Wire and Cable

Sponsor

**Insulated Conductors Committee
of the
IEEE Power Engineering Society**

Approved 21 May 1996

IEEE Standards Board

Abstract: Criteria and test methods for determining the compatibility of cable-pulling lubricants (compounds) with cable jacket or other exterior cable covering are described in this standard. Cable-pulling lubricants are used to lower the tension on cable as it is pulled into conduit, duct, or directionally bored holes. Compatibility is important because lubricants should not negatively interact with the cables they lubricate. Compatibility of lubricants with a variety of common cable coverings is considered.

Keywords: cable, cable covering, cable jacket, cable pulling, compatibility, compound, dielectric withstand, immersion testing, lubricants, physical properties, volume resistance measurement, wire

The Institute of Electrical and Electronics Engineers, Inc.
345 East 47th Street, New York, NY 10017-2394, USA

Copyright © 1996 by the Institute of Electrical and Electronics Engineers, Inc.
All rights reserved. Published 1996. Printed in the United States of America.

ISBN 1-55937-725-9

No part of this publication may be reproduced in any form, in an electronic retrieval system or otherwise, without the prior written permission of the publisher.

IEEE Standards documents are developed within the IEEE Societies and the Standards Coordinating Committees of the IEEE Standards Board. Members of the committees serve voluntarily and without compensation. They are not necessarily members of the Institute. The standards developed within IEEE represent a consensus of the broad expertise on the subject within the Institute as well as those activities outside of IEEE that have expressed an interest in participating in the development of the standard.

Use of an IEEE Standard is wholly voluntary. The existence of an IEEE Standard does not imply that there are no other ways to produce, test, measure, purchase, market, or provide other goods and services related to the scope of the IEEE Standard. Furthermore, the viewpoint expressed at the time a standard is approved and issued is subject to change brought about through developments in the state of the art and comments received from users of the standard. Every IEEE Standard is subjected to review at least every five years for revision or reaffirmation. When a document is more than five years old and has not been reaffirmed, it is reasonable to conclude that its contents, although still of some value, do not wholly reflect the present state of the art. Users are cautioned to check to determine that they have the latest edition of any IEEE Standard.

Comments for revision of IEEE Standards are welcome from any interested party, regardless of membership affiliation with IEEE. Suggestions for changes in documents should be in the form of a proposed change of text, together with appropriate supporting comments.

Interpretations: Occasionally questions may arise regarding the meaning of portions of standards as they relate to specific applications. When the need for interpretations is brought to the attention of IEEE, the Institute will initiate action to prepare appropriate responses. Since IEEE Standards represent a consensus of all concerned interests, it is important to ensure that any interpretation has also received the concurrence of a balance of interests. For this reason, IEEE and the members of its societies and Standards Coordinating Committees are not able to provide an instant response to interpretation requests except in those cases where the matter has previously received formal consideration.

Comments on standards and requests for interpretations should be addressed to:

Secretary, IEEE Standards Board
445 Hoes Lane
P.O. Box 1331
Piscataway, NJ 08855-1331
USA

Note: Attention is called to the possibility that implementation of this standard may require use of subject matter covered by patent rights. By publication of this standard, no position is taken with respect to the existence or validity of any patent rights in connection therewith. The IEEE shall not be responsible for identifying all patents for which a license may be required by an IEEE standard or for conducting inquiries into the legal validity or scope of those patents that are brought to its attention.

Authorization to photocopy portions of any individual standard for internal or personal use is granted by the Institute of Electrical and Electronics Engineers, Inc., provided that the appropriate fee is paid to Copyright Clearance Center. To arrange for payment of licensing fee, please contact Copyright Clearance Center, Customer Service, 222 Rosewood Drive, Danvers, MA 01923 USA; (508) 750-8400. Permission to photocopy portions of any individual standard for educational classroom use can also be obtained through the Copyright Clearance Center.

Introduction

(This introduction is not part of IEEE Std 1210-1996, IEEE Standard Tests for Determining Compatibility of Cable-Pulling Lubricants With Wire and Cable.)

Cable-pulling lubricants (compounds) are used to lower the tension on cable as it is pulled into conduit, duct, or directionally bored holes. These friction reducers play an important part in minimizing physical damage to cable as it is installed.

It is important that lubricants do not negatively affect the cables they lubricate. Conventional oils and greases are generally not suitable pulling lubricants, since they can swell and weaken plastic jackets and insulations.

The purpose of this standard is to provide criteria and test methods for determining the compatibility of cable-pulling lubricants with cable jacket or other exterior cable covering. Until now, the evaluation of this compatibility was done on a nonstandard basis.

It should be noted that compatibility of lubricants with cable coverings is the only subject for the standard; other important performance criteria for lubricants, such as friction reduction, toxicity, combustibility, etc., are not discussed.

At the time this draft was completed, the Task Group on Cable-Pulling Compound Compatibility With Wire and Cable had the following membership:

John M. Fee, *Chair*

Thamir J. Al-Hussaini
Jim Brioty
Kent Brown
Rick Bush
Michael M. Dorn
Ken Fender
Stephen L. Fitzhugh
Bob Fulcomer
Ajit K. Gwal
Stan Harper
Rick Hartlein
Stan Howell
John Jeanmonod

W. F. Jensen
Ronnie Kirven
Mike Kopchik, Jr.
Frank LaGase
Jeffrey J. LaMarca
Don Learned
Rodney Machac
Sam Marcovi
T. M. McCauley
John Merando, Jr.
Dave Orchard
Ron Petersen

Wiley J. Pickett
George R. Pitman
Sam Rogoff
Stephen J. Sandburg
Wendell T. Starr
Joseph L. Steiner
Tom Stewart
Mike Sweat
Jack Tuzinski
T. T. A. Venkataraman
Joseph Waligorski
Olin L. Willis
Bob Washburn

Other individuals who have contributed review and comments are as follows:

Anthony Barlow
John E. Bramfitt
Gene D'Aquanno
James C. Dedman
Louis G. Delvalle
James V. Fitzgerald
Robert Fleming
D. A. Gillies
Eugene J. Hibbard
Darrell Jeter

Joseph S. Jue
Larry Kelly
Thomas J. Kendrew
James Kopcso
Ralph Lieux
Mark E. Lowell
Nicholas Lucio
Mel Maringer
Andy Melzer
Frank D. Meyers

Jim Moran
Ward C. Peterson
O. M. Rattan
George Remaley
Robert A. Resuali
Joseph H. Snow
D. J. Stonkus
William A. Thue
Robert O. Wilkenson
Walter Zenger

The following persons were on the balloting committee:

T. J. Al-Hussaini	R. W. Higginbottom	Ronald J. Ponist
R. W. Allen, Jr.	Lauri J. Hiivala	Paul F. Pugh
W. O. Andersen, Jr.	C. Katz	Peter Ralston
R. H. Arndt	L. J. Kelly	Greg P. Rampley
T. P. Arnold	F. E. Kimsey	Robert A. Resuali
T. A. Balaska	Joel Kitchens	R. B. Robertson
Anthony Barlow	H. T. Knox	Ralph W. Samm
Charles W. Blades	Frederick B. Koch	E. L. Sankey
David T. Bogden	Albert Kong	George W. Seman
Vincent J. Boliver	Donald E. Koonce	John F. Shimshock
R. R. Borowski	M. Kopchik, Jr.	Bynum E. Smith
Ken E. Bow	F. E. La Fetra	Joseph H. Snow
John E. Bramfitt	F. E. La Gase	T. F. Stabosz
M. D. Buckweitz	Jeffrey J. La Marca	Wendall T. Starr
R. R. Burghardt	Carl Landinger	Joseph L. Steiner
Paul S. Cardello	J. S. Lasky	Grover L. Stell, Jr.
John L. Carlson	Jack H. Lawson	Frank M. Stepniak
Charles White	Raoul H. Leuteritz	George A. Straniero
Paul L. Cinquemani	T. H. Ling	Mike D. Sweat
Wayne E. Cole	John V. Lipe	Keith W. Switzer
E. J. D'Aquanno	Mark E. Lowell	John Tanaka
S. J. Dale	G. Ludasi	James W. Tarpey
J. M. Daly	R. Luther	Frank A. Teti
Russ Dantzler	G. J. Luzzi	H. D. Thomas
Joseph A. Di Costanzo	Jeffry P. Mackevich	William A. Thue
C. Doench	G. Allen MacPhail	Austin C. Tingley
J. P. Dupont	M. A. Martin	William Torok
G. S. Eager, Jr.	I. J. Marwick	Duc B. Trinh
R. M. Eichhorn	M. S. Mashikian	S. E. Turner
Hussein El Badaly	S. G. Mastoras	Jack R. Tuzinski
J. S. Engelhardt	F. M. McAvoy	Donald A. Voltz
S. L. Fitzhugh	A. R. McCulloch	C. F. Von Hermann, Jr.
A. Fitzpatrick	E. J. McGowan	Richard L. Votoupal
E. O. Forster	A. L. McKean	Michael L. Walker
Ronald F. Frank	W. J. McNulty	Steven P. Walldorf
R. D. Fulcomer	J. D. Medek	Edward M. Walton
J. B. Gardner	David J. Mintz	Daniel J. Ward
P. Gazzana-Priaroggia	J. A. Moran, Jr.	Roldan H. W. Watkins
R. B. Gear	D. J. Nichols	A. C. Westrom
A. Godoshian	Harry E. Orton	Charles A. White
A. Gwal	J. J. Pachot	William D. Wilkens
Stan V. Harper	Cutter D. Palmer	Robert O. Wilkinson
R. Hartlein	Keith A. Petty	J. A. Williams
H. C. Hervig, Jr.	James J. Pickering	William G. Wimmer
S. V. Heyer	Jan S. Pirrong	J. T. Zimnoch
	Gary A. Polhill	

When the IEEE Standards Board approved this standard on 21 March 1996, it had the following membership:

Donald C. Loughry, *Chair*

Richard J. Holleman, *Vice Chair*

Andrew G. Salem, *Secretary*

Gilles A. Baril
Clyde R. Camp
Joseph A. Cannatelli
Stephen L. Diamond
Harold E. Epstein
Donald C. Fleckenstein
Jay Forster*
Donald N. Heirman

Ben C. Johnson
E. G. "Al" Kiener
Joseph L. Koepfinger*
Lawrence V. McCall
L. Bruce McClung
Marco W. Migliaro
Mary Lou Padgett
John W. Pope
Jose R. Ramos

Arthur K. Reilly
Ronald H. Reimer
Gary S. Robinson
Ingo Rüsçh
John S. Ryan
Chee Kiow Tan
Leonard L. Tripp
Howard L. Wolfman

*Member Emeritus

Also included are the following nonvoting IEEE Standards Board liaisons:

Satish K. Aggarwal
Alan H. Cookson
Chester C. Taylor

Paula M. Kelty
IEEE Standards Project Editor

Contents

CLAUSE	PAGE
1. Overview.....	1
1.1 Scope	1
1.2 Purpose	1
2. References.....	2
3. Physical property effects.....	2
3.1 General	2
3.2 Lubricant on polyvinyl chloride (PVC) jacket	2
3.3 Lubricant on black polyethylene (PE) jacket	3
3.4 Lubricant on thermoplastic chlorinated polyethylene (CPE) jacket.....	3
3.5 Lubricant on natural rubber jacket	3
3.6 Lubricant on styrene butadiene rubber (SBR) jacket	4
3.7 Lubricant on thermoset polychloroprene jacket	4
3.8 Lubricant on acrylonitrile/butadiene and polyvinyl chloride (PVC) jacket	4
3.9 Lubricant on a thermoset chlorosulfonated polyethylene (CSPE) jacket.....	5
3.10 Lubricant on thermoset chlorinated polyethylene (CPE) jacket.....	5
4. Electrical property effects	6
4.1 General	6
4.2 Lubricant on semiconducting jackets or exposed semiconducting shields	6
4.3 Determining stability of lubricant on semiconducting materials	6
4.4 Final high-temperature volume resistivity test	7
4.5 Lubricant on exposed thermoplastic primary insulation	7
4.6 Lubricant on exposed thermoset primary insulation	8
5. Testing and test methods.....	9
5.1 General	9
5.2 Jacket test specimens for the immersion/physical property tests	9
5.3 Tensile strength and elongation test	9
5.4 Heated lubricant immersion method	10
5.5 Heated water/air immersion method	10
5.6 Environmental stress cracking test	10
5.7 Specimens for volume resistivity tests (stability and final high temperature)	11
5.8 Specimens and test for semiconducting jacket and self-supporting lubricants	11
5.9 Specimens and tests for semiconducting insulation shield with self-supporting lubricants ...	11
5.10 Volume resistivity test procedure for self-supporting lubricants on semiconducting jackets/shields.....	12
5.11 Specimens and tests for semiconducting jackets/shields when lubricants are not self-supporting—immersion test	13
5.12 Preparation of samples for the dielectric voltage withstand test in water	13
5.13 Dielectric voltage withstand test in water	13
Annex A (informative) Bibliography.....	14

IEEE Standard Tests for Determining Compatibility of Cable-Pulling Lubricants With Wire and Cable

1. Overview

1.1 Scope

This standard applies to cable-pulling lubricants (compounds) and the testing and analysis of their interaction with wire and cable. Cable-pulling lubricants are used to lower the tension on cables when they are installed (pulled) into conduits, ducts, or directionally bored holes. These lubricants and/or their residues are in direct contact with the cable exterior covering and may remain so for the life of the cable. Cable-pulling lubricants should be compatible with the cable. They should not interfere with the function of any component of the cable system that they contact.

Compatibility of cable-pulling lubricants with cable coverings is the only subject of this standard; other important performance criteria for cable-pulling lubricants, such as friction reduction, toxicity, combustibility, etc., are not discussed.

This standard utilizes accepted cable performance standards whenever possible. Relevant standards are cited in the text and listed in clause 2.

1.2 Purpose

This standard describes tests for determining the compatibility of cable-pulling lubricants with cable jacket or other exterior cable covering. Compatibility of cable-pulling lubricants with a variety of common cable coverings is considered.

Often, testing is confined to the effect of the lubricant on the physical properties of the jacket. When the electrical properties, such as dielectric withstand voltage or electrical resistivity, are important, the evaluation also includes these properties.

2. References

This standard shall be used in conjunction with the following publications. When the following standards are superseded by an approved revision, the revision shall apply:

ANSI/UL 83-1991, Thermoplastic-Insulated Wires and Cables.¹

ANSI/UL 1581-1991, Reference Standard for Electrical Wires, Cables, and Flexible Cords.

ASTM D412-92E2, Standard Test Methods for Vulcanized Rubber and Thermoplastic Rubbers and Thermoplastic Elastomers—Tension.²

ASTM D1693-95, Standard Test Method for Environmental Stress-Cracking of Ethylene Plastics.

3. Physical property effects

3.1 General

Evaluation shall consist of immersing the cable jacket in the cable-pulling lubricant and heat-aging the cable jacket while immersed at two different temperatures for two different durations in order to determine physical property changes. The results of this evaluation shall be compared to unimmersed and unaged samples at the first temperature and to heat-aged comparison samples at both temperatures. The heat-aged comparison samples shall be water-immersed (for cables suitable for use in a wet or damp environment) or air-aged (for cables not so suited).

To accurately establish a lubricant's compatibility with a cable jacket, priority should be given to testing the specific cable jacket lubricant that is intended for use, since the lubricant on generic types of cable jackets can vary significantly.

Reported results shall include the date of testing and identification of, and specific information about, the cable or jacket compound tested.

3.2 Lubricant on polyvinyl chloride (PVC) jacket

When tested on PVC jacket in accordance with the immersion test of clause 5, the lubricant shall not affect the jacket in excess of the following:

After immersion test at $100\text{ }^{\circ}\text{C} \pm 1\text{ }^{\circ}\text{C}$ for 5 days (NEMA WC5-1992 [B8]³, 4.3.2.1)

- Tensile strength retained
Minimum percent of unimmersed and unaged comparison value—85%
- Elongation at break retained
Minimum percent of unimmersed and unaged comparison value—60%
- Tensile strength and elongation at break retained
Minimum percent of immersed in water/air and heat-aged comparison value—85%

¹UL publications are available from Underwriters Laboratories, Inc., 333 Pfingsten Road, Northbrook, IL 60062-2096, USA.

²ASTM publications are available from the Customer Service Department, American Society for Testing and Materials, 100 Barr Harbor Drive, West Conshohocken, PA 19428-2959, USA.

³The numbers in brackets preceded by the letter B correspond to those of the bibliography in annex A.

After immersion test at $50\text{ }^{\circ}\text{C} \pm 1\text{ }^{\circ}\text{C}$ for 30 days

- Tensile strength and elongation at break retained
Minimum percent of immersed in water/air and heat-aged comparison value—85%

3.3 Lubricant on black polyethylene (PE) jacket

When tested on black PE jacket in accordance with the immersion and environmental stress crack tests of clause 5, the lubricant shall not affect the jacket in excess of the following:

After immersion test at $100\text{ }^{\circ}\text{C} \pm 1\text{ }^{\circ}\text{C}$ for 48 h (NEMA WC5-1992 [B8], 4.3.2.2)

- Tensile strength retained
Minimum percent of unimmersed and unaged comparison value—75%
- Elongation at break retained
Minimum percent of unimmersed and unaged comparison value—75%
- Tensile strength and elongation at break retained
Minimum percent of immersed in water/air and heat-aged comparison value—85%

After immersion test at $50\text{ }^{\circ}\text{C} \pm 1\text{ }^{\circ}\text{C}$ for 30 days

- Tensile strength and elongation at break retained
Minimum percent of immersed in water/air and heat-aged comparison value—85%

After environmental stress crack test immersed in lubricant at $50\text{ }^{\circ}\text{C} \pm 1\text{ }^{\circ}\text{C}$ for 48 h

- Maximum percent of samples cracked—20%

3.4 Lubricant on thermoplastic chlorinated polyethylene (CPE) jacket

When tested on a thermoplastic CPE jacket in accordance with the immersion test of clause 5, the lubricant shall not affect the jacket in excess of the following:

After immersion test at $100\text{ }^{\circ}\text{C} \pm 1\text{ }^{\circ}\text{C}$ for 5 days (NEMA WC5-1992 [B8], 4.3.2.3)

- Tensile strength retained
Minimum percent of unimmersed and unaged comparison value—85%
- Elongation at break retained
Minimum percent of unimmersed and unaged comparison value—50%
- Tensile strength and elongation at break retained
Minimum percent of immersed in water/air and heat-aged comparison value—85%

After immersion test at $50\text{ }^{\circ}\text{C} \pm 1\text{ }^{\circ}\text{C}$ for 30 days

- Tensile strength and elongation at break retained
Minimum percent of immersed in water/air and heat-aged comparison value—85%

3.5 Lubricant on natural rubber jacket

When tested on a vulcanized jacket containing at least 60% natural rubber in accordance with the immersion test of clause 5, the lubricant shall not affect the jacket in excess of the following:

After immersion test at $70\text{ }^{\circ}\text{C} \pm 1\text{ }^{\circ}\text{C}$ for 96 h (NEMA WC3-1992 [B7], 4.13)

- Minimum tensile strength—2500 lbf/in²
Minimum elongation at break—400%
- Tensile strength and elongation at break retained
Minimum percent of immersed in water/air and heat-aged comparison value—85%

After immersion test at $50\text{ }^{\circ}\text{C} \pm 1\text{ }^{\circ}\text{C}$ for 30 days

- Tensile strength and elongation at break retained
Minimum percent of immersed in water/air and heat-aged comparison value—85%

3.6 Lubricant on styrene butadiene rubber (SBR) jacket

When tested on an SBR jacket in accordance with the immersion test of clause 5, the lubricant shall not affect the jacket in excess of the following:

After immersion test at $70\text{ }^{\circ}\text{C} \pm 1\text{ }^{\circ}\text{C}$ for 168 h (NEMA WC3-1992 [B7], 4.13)

- Minimum tensile strength—1600 lbf/in²
Minimum elongation at break—250%
- Tensile strength and elongation at break retained
Minimum percent of immersed in water/air and heat-aged comparison value—85%

After immersion test at $50\text{ }^{\circ}\text{C} \pm 1\text{ }^{\circ}\text{C}$ for 30 days

- Tensile strength and elongation at break retained
Minimum percent of immersed in water/air and heat-aged comparison value—85%

3.7 Lubricant on thermoset polychloroprene jacket

When tested on a thermoset polychloroprene jacket in accordance with the immersion test of clause 5, the lubricant shall not affect the jacket in excess of the following:

After immersion test at $100\text{ }^{\circ}\text{C} \pm 1\text{ }^{\circ}\text{C}$ for 168 h (NEMA WC3-1992 [B7], 4.13)

- Tensile strength and elongation at break retained
Minimum percent of unimmersed and unaged comparison value—50%
- Tensile strength and elongation at break retained
Minimum percent of immersed in water/air and heat-aged comparison value—85%

After immersion test at $50\text{ }^{\circ}\text{C} \pm 1\text{ }^{\circ}\text{C}$ for 30 days

- Tensile strength and elongation at break retained
Minimum percent of immersed in water/air and heat-aged comparison value—85%

3.8 Lubricant on acrylonitrile/butadiene and polyvinyl chloride (PVC) jacket

When tested on a thermoset blend of acrylonitrile/butadiene rubber and PVC resin in accordance with the immersion test of clause 5, the lubricant shall not affect the jacket in excess of the following:

After immersion test at $100\text{ }^{\circ}\text{C} \pm 1\text{ }^{\circ}\text{C}$ for 168 h (NEMA WC3-1992 [B7], 4.13)

- Tensile strength and elongation at break retained
Minimum percent of unimmersed and unaged comparison value—50%
- Tensile strength and elongation at break retained
Minimum percent of immersed in water/air and heat-aged comparison value—85%

After immersion test at $50\text{ }^{\circ}\text{C} \pm 1\text{ }^{\circ}\text{C}$ for 30 days

- Tensile strength and elongation at break retained
Minimum percent of immersed in water/air and heat-aged comparison value—85%

3.9 Lubricant on a thermoset chlorosulfonated polyethylene (CSPE) jacket

When tested on a thermoset CSPE jacket in accordance with the immersion test of clause 5, the lubricant shall not affect the jacket in excess of the following:

After immersion at $100\text{ }^{\circ}\text{C} \pm 1\text{ }^{\circ}\text{C}$ for 168 h (NEMA WC3-1992 [B7], 4.13)

- Tensile strength retained
Minimum percent of unimmersed and unaged comparison value—85%
- Elongation at break retained
Minimum percent of unimmersed and unaged comparison value—65%
- Tensile strength and elongation at break retained
Minimum percent of immersed in water/air and heat-aged comparison value—85%

After immersion test at $50\text{ }^{\circ}\text{C} \pm 1\text{ }^{\circ}\text{C}$ for 30 days

- Tensile strength and elongation at break retained
Minimum percent of immersed in water/air and heat-aged comparison value—85%

3.10 Lubricant on thermoset chlorinated polyethylene (CPE) jacket

When tested on a thermoset CPE jacket in accordance with the immersion test in clause 5, the lubricant shall not affect the jacket in excess of the following:

After immersion test at $100\text{ }^{\circ}\text{C} \pm 1\text{ }^{\circ}\text{C}$ for 168 h (NEMA WC3-1992 [B7], 4.13)

- Tensile strength retained
Minimum percent of unimmersed and unaged comparison value—85%
- Elongation at break retained
Minimum percent of unimmersed and unaged comparison value—65%
- Tensile strength and elongation at break retained
Minimum percent of immersed in water/air and heat-aged comparison value—85%

After immersion test at $50\text{ }^{\circ}\text{C} \pm 1\text{ }^{\circ}\text{C}$ for 30 days

- Tensile strength and elongation at break retained
Minimum percent of immersed in water/air and heat-aged comparison value—85%

4. Electrical property effects

4.1 General

This clause shall only apply when the lubricant is used on coverings that are semiconducting or unshielded cables with exposed primary insulation (building wire or special purpose cables).

4.2 Lubricant on semiconducting jackets or exposed semiconducting shields

The lubricant shall not cause the volume resistivity to exceed AEIC specifications [B1–B3] or ICEA standards [B7–B12]. The lubricants shall demonstrate stability over a minimum 42-day test before the final high-temperature test. The final high-temperature test includes temperatures (table 2) to represent the transient high temperatures possible from overloading.

4.3 Determining stability of lubricant on semiconducting materials (IEEE Std 1026-1995 [B13])

When tested according to table 1 and clause 5, for a minimum duration of 42 days, effect of the lubricant on the semiconducting material shall show stability if it meets the following equation:

$$3 \log P_n \leq \log P_{(n-14)} + \log P_{(n-28)} + \log P_{(n-42)} + 0.3 \quad (1)$$

where

P is the volume resistivity measured in accordance with clause 5 on the n th, n th–14, n th–28, and n th–42 days

NOTE—When $n = 42$ days, the 1-day P reading should be used for $P(n-42)$.

Volume resistivity readings shall be made on a schedule as follows: Samples shall be pre-aged for 18 h at the temperature specified in table 1, then cooled before the initial (0) reading.

Initial (0), 1, 3, 7, 14, 28, and 42 days' aging at the temperature specified in table 1. All samples will be cooled to 20–30 °C (± 2 °C of the same temperature for all readings) to measure resistance, then returned to the oven for additional aging. In all cases, readings shall not be taken sooner than 4 h after removal from the oven.

Table 1—Aging temperature for volume resistivity samples

Sample type	75 °C rated cable	90 °C rated cable
Conducting jacket	75 °C \pm 2 °C	90 °C \pm 2 °C
Exposed insulation shield	75 °C \pm 2 °C	90 °C \pm 2 °C

If, at the 42-day reading, stability is not demonstrated as defined in equation 1, then aging shall be continued and readings shall be made at additional 14-day intervals until stability is attained, or for 92 days.

All volume resistivity calculations shall be recorded, including the initial (unaged) P_o and final P_n . If any volume resistivity determined during the aging was greater than the final P_n , then the ratio of how much greater shall be determined as follows:

$$K = \frac{P_G}{P_n} \quad (2)$$

where

K is the ratio (always greater than 1)

P_G is the greatest volume resistivity measured

P_n is the final volume resistivity measured

4.4 Final high-temperature volume resistivity test (AEIC CS5-94 [B1], AEIC CS6-96 [B2], AEIC CS7-93 [B3], and IEEE Std 1026-1995 [B13])

On completion of the stability testings and attainment of stability, a final volume resistivity shall be determined in accordance with clause 5 at the test temperatures in table 2.

Table 2—Final volume resistivity test temperature and maximums

Sample type	Test temperature	Maximum volume resistivity
Conductive jacket	75 °C ± 2 °C	50 000 Ω-cm
	and 90 °C ± 2 °C	50 000 Ω-cm
Exposed insulation shield on thermoplastic polyethylene insulation	75 °C ± 2 °C	50 000 Ω-cm
	and 90 °C ± 2 °C	50 000 Ω-cm
Exposed insulation shield on cross-linked polyethylene insulation	90 °C ± 2 °C	50 000 Ω-cm
	and 110 °C ± 2 °C	50 000 Ω-cm
Exposed insulation shield on ethylene propylene rubber insulation	90 °C ± 2 °C	50 000 Ω-cm
	and 110 °C ± 2 °C	50 000 Ω-cm

In no case shall the volume resistivity determined at the final test temperature, or any volume resistivity determined in 4.3, or K times the volume resistivity at the final test temperature (see equation 2 for determination of K), exceed the maximum values given in table 2.

4.5 Lubricant on exposed thermoplastic primary insulation

When tested on exposed thermoplastic primary insulation in accordance with the dielectric voltage-withstand test of clause 5, the lubricant shall not affect the exposed insulation so that the insulation cannot withstand, for 60 s, without breakdown, the essentially sinusoidal rms test potentials given in table 3 (ANSI/UL 83-1991⁴). Tests can be run on any conductor size in table 3 to meet the requirements of this section for that exposed insulation type.

Table 3—RMS test potential in volts—thermoplastic-exposed insulation

Conductor size	Type			
	THW, THWN, THHN (600 V)	T, TW (600 V)	FEP, FEPB (600 V)	TFE (600 V)
14–9 AWG	2000	1500	2000	2000
8–2 AWG	2000	2000	2000	2000
1–4/0 AWG	2500	2500	—	2000
250–500 kcmil	3000	3000	—	—
550–1000 kcmil	3500	3500	—	—
1100–2000 kcmil	4000	4000	—	—

4.6 Lubricant on exposed thermoset primary insulation

When tested on exposed thermoset primary insulation in accordance with the dielectric voltage-withstand test of clause 5, the lubricant shall not affect the exposed insulation so that the insulation cannot withstand, for 60 s, without breakdown, the essentially sinusoidal rms test potentials given in table 4 (ANSI/UL 44-1991 [B4]). Tests can be run on any conductor size in table 4 to meet the requirements of this subclause for that exposed insulation type.

Table 4—RMS potential in volts—thermoset exposed insulation

Conductor size	Types			
	RHW, RHH, XHHW, SA (600 V)	RH (600 V)	RH, RHW, RHH (2000 V)	SIS (600 V)
13–11 AWG	3000	2000	6 000	3000
10, 9 AWG	3000	3000	6 000	3000
8 AWG	3500	3500	6 000	3500
7 AWG	3500	3500	7 500	3500
6–2 AWG	3500	3500	7500	3500
1–4/0 AWG	4000	4000	9 000	4000
250–500 kcmil	5000	5000	10 000	—
500–1000 kcmil	6000	6000	11 000	—
1100–2000 kcmil	7000	7000	11 000	—

⁴Information on references can be found in clause 2.

5. Testing and test methods

5.1 General

Tests shall be performed using the cable-pulling lubricant and the jacket for which compatibility is being determined. Both lubricant and jacket samples should be representative and selected at random.

5.2 Jacket test specimens for the immersion/physical property tests

Specimens shall be taken from completed wire or cable. Fifteen specimens of the jacket shall be taken for the test. Three will serve as unimmersed and unaged comparison samples, three will be immersed in lubricant at the first temperature, three will be immersed at the second temperature, three will serve as the aged in air/water comparison samples at the first temperature, and three will serve as the aged in air/water comparison at the second temperature. The specimens shall be segment cut with a sharp knife or with a Die C or D, as specified by ASTM D412-92E2. The specimens shall be cut parallel to the cable axis and shall not have a cross-sectional area greater than .025 in² or less than .0075 in² after irregularities, corrugations, and reinforcing members have been removed. If necessary, surface irregularities shall be removed so that the specimens are smooth and of uniform thickness.

5.3 Tensile strength and elongation test

Physical tests shall be performed at room temperature (68–82 °F) on a tensile testing machine that is in accordance with ASTM D412-92E2.

The test specimens, prepared in accordance with 5.2, shall be marked with gauge marks that are 1 in apart. The jaws of the testing machine shall be a maximum of 4 in apart. The separation speed shall be 20 in/min, continued until the specimen breaks. However, if the test specimen is polyethylene, the maximum jaw separation will be 2.5 in and the speed will be 2 in/min. The tensile strength shall be calculated from the force at break and the cross-sectional area of the *unstretched* specimen.

Elongation at break shall be determined at the same time as tensile strength. The distance between the gauge marks at break shall be measured and used to calculate the elongation at break as follows:

$$E = \frac{(G_R - G_o)}{G_o} \cdot 100 \quad (3)$$

where

- E is the elongation at break
- G_R is the gauge mark distance at rupture
- G_o is the original gauge mark distance

Results of tensile and elongation tests will be the average from three specimens called for in 5.2 at the various aging conditions. Specimens length and type, gauge mark distance, and jaw separation and speed will be recorded with the results.

5.4 Heated lubricant immersion method

The purpose of the heated immersion of the specimens in the cable-pulling lubricant is to determine the effect of the lubricant on the cable jacket material. The lubricant should be used in the same form and concentration that it would be used in pulling cable.

350 ml of lubricant shall be placed in a glass desiccator with an opening in the lid for a no. 8 rubber stopper. The desiccator shall have a flange I.D. of 200 mm and a chamber depth of 125 mm.⁵ The 350 ml shall fill the desiccator to a lubricant depth of approximately 10 mm.

The three physical test specimens called for in 5.2 shall be completely immersed in the lubricant.

The lid shall be placed on the desiccator and a no. 8, one-hole, rubber stopper (hole diameter of 5 mm) shall be placed in the lid opening. Volatiles in the lubricant can slowly escape through the stopper, as they do from a conduit.

The desiccator, with immersed test specimens, will be heated for the specified time and temperature (refer to 3.2–3.10) in a fresh-air-circulating oven.

At the end of the test period, the specimens shall be removed from the desiccator. They shall be carefully and thoroughly washed with tap water to remove lubricant residue, then blotted dry. The specimens shall be allowed to rest at room temperature for a minimum of 48 h and a maximum of 96 h before physical testing. The tensile and elongation of the samples shall then be determined in accordance with 5.3. The physical properties of the comparison samples shall be determined at the same time.

5.5 Heated water/air immersion method

The purpose of the heated immersion of the specimens in water (for cable suitable for wet or damp locations) or air is to provide a comparison sample for the lubricant-immersed samples described in 5.4.

The procedure is the same as in 5.4 except that either distilled water or nothing is placed in the glass desiccator.

The aging for the water-/air-immersed samples should be identical to the lubricant-immersed samples and should be performed at the same time.

The conditioning before physical testing shall also be identical to the lubricant-immersed samples.

5.6 Environmental stress cracking test

Except as noted below, this test shall be conducted in accordance with Condition A, specified in ASTM D1693-95.

The test specimens shall come from platen moldings of PE jacket material taken from completed cable. The temperature of the newly molded samples shall be lowered at the rate specified in ASTM D1928-90 [B6], Procedure C. Ten samples shall be razor slit (ASTM D1693-95, Condition A) and completely immersed in lubricant in a test tube 200 mm long and 32 mm in diameter. An additional set of 10 control samples shall be similarly slit and completely immersed in distilled water in a similar test tube. Both test tubes shall be sealed with a foil-covered cork. At the end of the test period, both sets of specimens shall be removed, allowed to cool to room temperature, and inspected for cracking. No interim inspection is necessary. The water-immersed control samples provide perspective on reasons for cracking if any occurs.

⁵Pyrex Brand 3100200 desiccator and lid, or equivalent.

5.7 Specimens for volume resistivity tests (stability and final high temperature)

The lubricant (or its residue) must remain in contact with the semiconducting jacket or exposed semiconducting insulation shield for the 42-day (or longer) duration of the test. Three types of tests are described: one, when the lubricant will stay in place by itself on conductive jacket; one, when the lubricant will stay in place by itself on semiconducting insulation shield; and the final test, when the lubricant will not stay in place (too fluid to maintain a 3 mm thick coating girdling the cable).

5.8 Specimens and test for semiconducting jacket and self-supporting lubricants

Test procedures shall be performed in the following way: Cut two cable specimens 230 mm long. Remove from the cable the semiconducting jacket and all other coverings to expose the dielectric. Cut the semiconducting jacket so that it fits snugly over the dielectric with edges butting (gap no greater than 2 mm). Bind the jacket to the cable core using splicing tape on the outside 2 cm of both ends. Cut two pieces of cross-linked polyethylene, heat-shrinkable tubing, 158 mm in length, that is between 65% and 85% of the diameter of the cable when the tubing is fully recovered. Paint two bands of conducting silver paint 6 mm wide at a separation of 165 mm (centered on the 230 mm specimen). Mark the center 50 mm of the specimen and, on one specimen only, place a lubricant coating of approximately 3 mm thickness completely around the cable in this 50 mm area. The second specimen serves as a control with no lubricant exposure. Shrink the tubing over the specimen working from both edges in. Final appearance and dimensions are shown in figure 1. As an alternative to heat-shrink tubing, self-adhering silicone rubber tape can also be wrapped to form the containment pocket shown in figure 1.

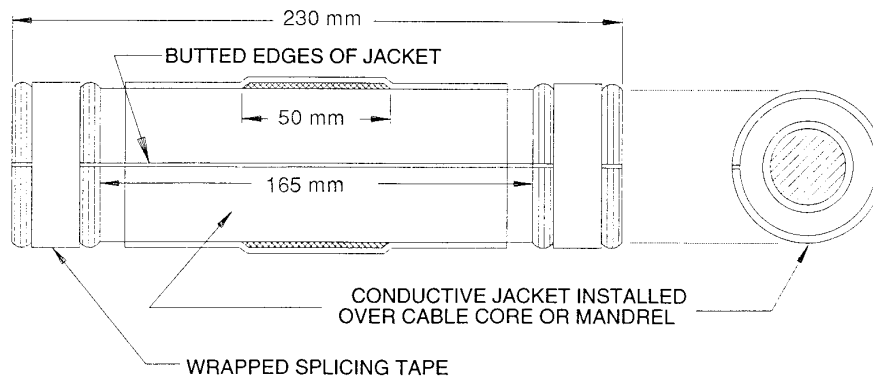

Figure 1—Specimen for self-supporting lubricants—conductive jacket

Test both specimens at the conditions specified in 4.3 and 4.4 and by the method in 5.10.

5.9 Specimens and tests for semiconducting insulation shield with self-supporting lubricants

Test procedures shall be performed in the following way: Cut two cable specimens 230 mm long. Remove all coverings down to the semiconducting insulation shield (in most cases, the concentric neutral wires are the only coverings that need to be removed). Cut two pieces of cross-linked polyethylene, heat-shrinkable tubing (without internal sealant) to 158 mm inches in length. Choose heat-shrinkable tubing that is between 65% and 85% of the diameter of the cable when the tubing is fully recovered. Paint two bands of conducting silver paint 6 mm wide at a separation of 165 mm inches (centered on the 230 mm specimen). Mark the cen-

ter 50 mm of the specimen and on one specimen only, place a lubricant coating of approximately 3 mm thickness completely around the cable in this 50 mm area. The second specimen serves as a control with no lubricant exposure. Shrink the tubing over the specimen working inward from both edges. Final appearance and dimensions are shown in figure 2. As an alternative to heat shrink tubing, self-adhering silicone rubber tape can also be wrapped to form the containment pocket shown in figure 2.

Test both specimens at the conditions specified in 4.3 and 4.4 and by the method in 5.10.

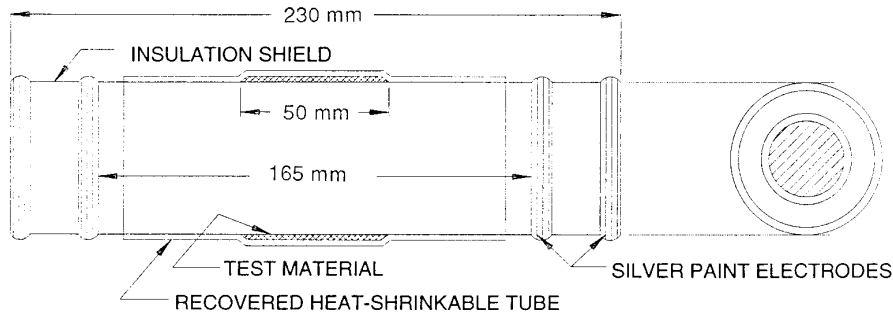

Figure 2—Specimen for self-supporting lubricants—exposed insulation shield

5.10 Volume resistivity test procedure for self-supporting lubricants on semiconducting jackets/shields

Two samples shall be prepared as in 5.8 or 5.9, one with lubricant and the other without lubricant, to serve as a comparison. Resistance measurements shall be taken using either the two-point method with an ohmmeter or the four-point method with current and potential electrodes. These tests shall be conducted as described in ICEA T-25-425. An initial reading shall be taken for both specimens before they are oven-aged. All additional readings are to be taken at the temperatures and times specified in 4.3 and 4.4.

Convert the resistance measurements taken above to volume resistivity using the following formula:

$$P(n, t) = \frac{R(D^2 - d^2)}{4L} \quad (4)$$

where

- P is the volume resistivity, in Ω -cm
- R is the measured resistance, in Ω
- D is the diameter over the conducting component, in cm
- d is the diameter under the conducting component, in cm
- L is the distance between the potential electrodes, in cm
- n is the day from start of aging
- t is the temperature at which resistivity was read

5.11 Specimens and tests for semiconducting jackets/shields when lubricants are not self-supporting—immersion test

Test procedures shall be performed in the following way: Cut two test specimens for testing from the conductive component of the cable with the long dimension parallel to the conductor. Cut strips of material Test procedures shall be performed in the following way: 190 mm ± 3 mm long by 10 mm ± 1 mm wide. Apply silver electrodes as shown in figure 3 with the potential electrodes at a separation of 100 mm and the current electrodes at a separation of 180 mm.

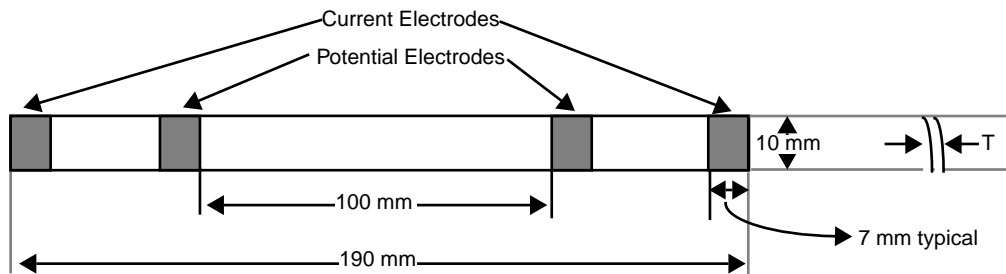

Figure 3—Specimen for non-self-supporting lubricants

Immerse one sample completely in lubricant at the conditions called for in 4.3 and 4.4 and test via the same method as in 5.10. The second sample should be air aged at the same conditions.

Convert the resistance measurements taken to volume resistivity using the equation:

$$P(n, t) = \frac{RWT}{L} \quad (5)$$

where

- P is the volume resistivity, in Ω -cm
- R is the measured resistance, in Ω
- W is the average width of the cut specimen (before immersion), in cm
- T is the thickness of specimen (before immersion), in cm
- L is the distance between the potential electrodes, in cm
- n is the day from start of aging
- t is the temperature at which resistivity was read

5.12 Preparation of samples for the dielectric voltage withstand test in water

A 10 ft (3.04 m) length of wire or cable shall be used for the test. The wire shall be coiled and immersed in the lubricant (closed container) for 30 days at 120 °F (49 °C). The coil shall then be removed from the lubricant, carefully and thoroughly washed, and allowed to dry for a minimum of 48 h and maximum of 96 h before the test.

5.13 Dielectric voltage withstand test in water

The test shall be run in accordance with ANSI/UL 1581-1991, Section 820, and the conditions in 4.5 or 4.6 with the following exceptions: A 10 ft (3.04 m) piece of cable shall be coiled for the test. The coil shall undergo the lubricant immersion preparation described in 5.12. The sample shall then be immersed in the water tank for 6 h before the test potential is applied.

Annex A

(informative)

Bibliography

[B1] AEIC CS5-94, Specifications for Cross-linked Polyethylene Insulated Shielded Power Cables Rated 5 through 46 kV.⁶

[B2] AEIC CS6-96, Specifications for Ethylene Propylene Rubber Insulated Shielded Power Cables Rated 5 through 69 kV.

[B3] AEIC CS7-93, Specifications for Cross-linked Polyethylene Insulated Shielded Power Cables Rated 69 through 138 kV.

[B4] ANSI/UL 44-1991, Rubber-Insulated Wires and Cables.⁷

[B5] ASTM D257-93, Test Methods for D-C Resistance for Conductance of Insulating Materials.⁸

[B6] ASTM D1928-90, Practice for Preparation of Compression-Molded Polyethylene Test Sheets and Test Specimens.

[B7] ICEA S-19-81/NEMA WC3-1992, Rubber Insulated Wire and Cable for the Transmission and Distribution of Electrical Energy.⁹

[B8] ICEA S-61-402/NEMA WC5-1992, Thermoplastic-Insulated Wire and Cable for the Transmission and Distribution of Electrical Energy.

[B9] ICEA S-66-524/NEMA WC7-1991, Cross-Linked-Thermosetting-Polyethylene-Insulated Wire and Cable for the Transmission and Distribution of Electrical Energy.

[B10] ICEA S-68-516/NEMA WC8-1991, Ethylene-Propylene-Rubber-Insulated Wire and Cable for the Transmission and Distribution of Electrical Energy.

[B11] ICEA S-73-532/NEMA WC57-1990, Standard for Control Cables.

[B12] ICEA T-25-425, Guide for Establishing Stability of Volume Resistivity for Conducting Polymeric Components of Power Cables.¹⁰

[B13] IEEE Std 1026-1995, IEEE Recommended Practice for Test Methods for Determination of Compatibility of Materials With Conductive Polymeric Insulation Shields and Jackets.¹¹

⁶AEIC publications are available from the Association of Edison Illuminating Companies, 600 N. 18th Street, P. O. Box 2641, Birmingham, AL 35291-0992, USA.

⁷UL publications are available from Underwriters Laboratories, Inc., 333 Pfingsten Road, Northbrook, IL 60062-2096, USA.

⁸ASTM publications are available from the Customer Service Department, American Society for Testing and Materials, 100 Barr Harbor Drive, West Conshohocken, PA 19428-2959, USA.

⁹ICEA/NEMA joint publications are available from the National Electrical Manufacturers Association, 1300 N. 17th St., Ste. 1847, Rosslyn, VA 22209, USA.

¹⁰ICEA publications are available from ICEA, P.O. Box 411, South Yarmouth, MA 02664, USA.

¹¹IEEE publications are available from the Institute of Electrical and Electronics Engineers, 445 Hoes Lane, P.O. Box 1331, Piscataway, NJ 08855-1331, USA.